

Monobloc and Sectional Directional Control Valves

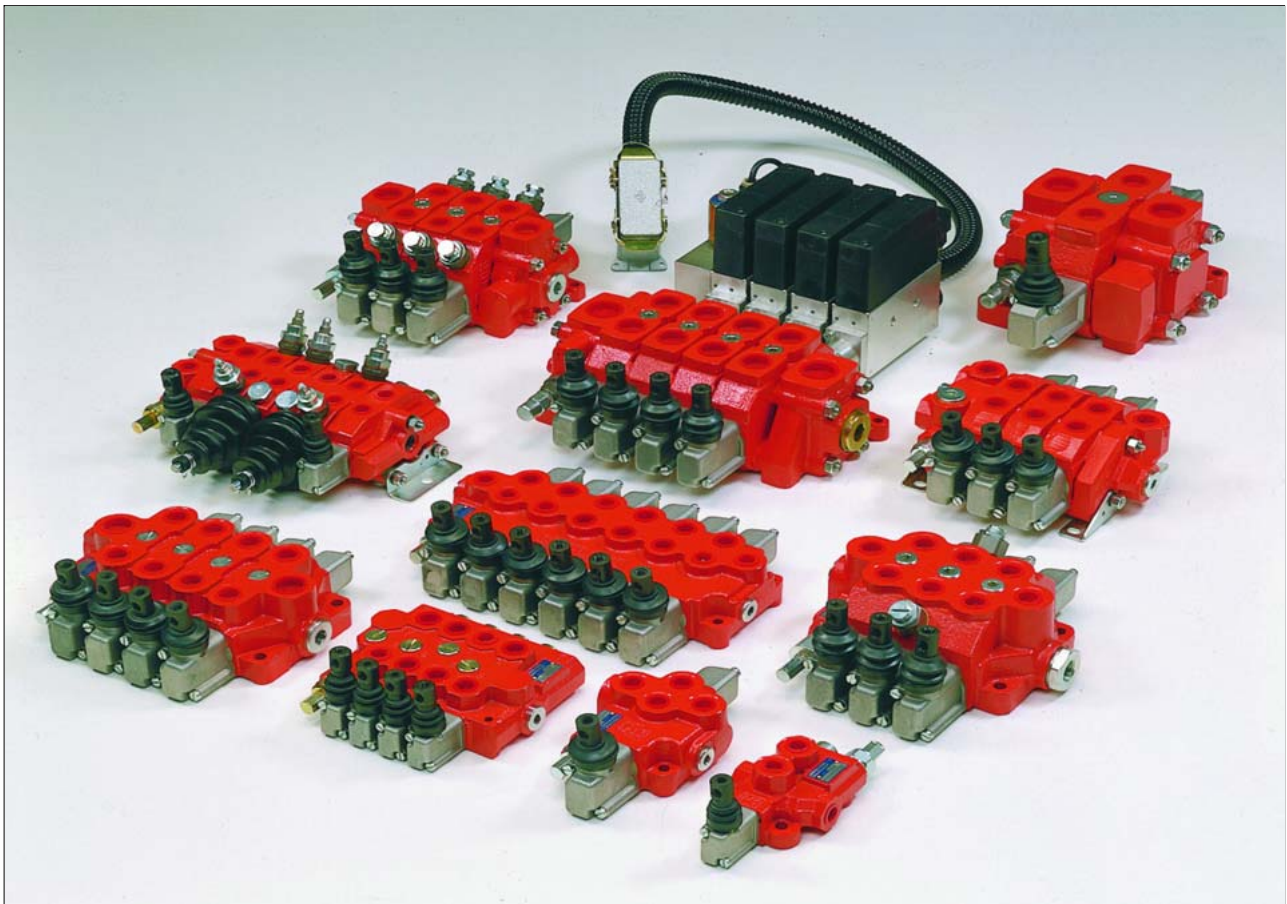

motion and progress

5 Monobloc directional control valves HDM18



Contents

5.1	General specifications	49
5.2	Dimensional data	50
5.3	Performances curves	51
5.4	Monobloc bodies	52
5.5	Adjustable direct acting Relief Valve RV	54
5.6	Spool charts	54
5.7	Load Sensing	55
5.8	Spool actions	56
5.9	Lever styles	57
5.10	Hydraulic-Pneumatic control ON-OFF	59
5.11	Pneumatic controls	59
5.12	Hydraulic Proportional control	60
5.13	Electro-Hydraulic controls	61
5.14	Solenoids for pilot electrovalves EHI-EHE	63

5.1 General specifications

Technical specification		
Max flow rate	l/min. U.S.G.P.M.	70 18
Max continuous operating pressure supply port P	bar PSI	350 5000
Max intermittent peak pressure Work port A/B	bar PSI	400 5800
Max back pressure tank port T	bar PSI	30 430
Oil temperature	° C ° F	-10 to 80 14 to 180
Oil viscosity	mm ² /s	16 to 75
Oil filtration	μ	≤ 30

Spool leakage at 100 bar (1450 PSI), Temp. 50° C (120° F), viscosity 27 mm ² /s:		
Maximum	cm ³ /min. Cu. In./min.	14 0.854
Average	cm ³ /min. Cu. In./min.	7 0.427
Lower values on demand (to be agreed with our Sales Dept.)		

Number of spools	1 to 4
Adjustable direct operated relief valve (tamper-proof seal available on request)	RV
Load hold check valve in each section	LC

5.1.1 Weight

Version	kg	lb
HDM18/1	4.3	9.60
HDM18/2	6.0	13.2
HDM18/3	9.0	19.8
HDM18/4	12.0	26.4

5.1.2 Material specification:

Body: High strength cast-iron.
Spool: Hardened steel and chrome plated
Seals: Buna "N".

5.1.3 Standard features:

- 1) Parallel circuit
- 2) Balanced interchangeable spools (provides minimum leakage, smooth operation)
- 3) Wide selection inlets, work ports, and outlets threaded ports.
- 4) Negative overlapping of the spool.

5.1.4 Optional features available:

- 1) Open or closed centre positions, 3 or 4 way operations, 3 or 4 position (float position), full open centre (motor spool) and other spool options.
- 2) Carry over.
- 3) Series circuit
- 4) Load Sensing circuit closed centre for variable displacement pump
- 5) Complete lever assembly
- 6) Wide range of positioners

5.1.5 Symbols:

P: inlet port
T: outlet port
A/B: work ports
H.P.C.O.: carry-over
RV: relief valve
P₁T₁: side inlet and outlet ports
 3.1.0.2: spool position
 P: pressure line
 T: exhaust line
 E: centre line (by pass).

5.2 Dimensional data

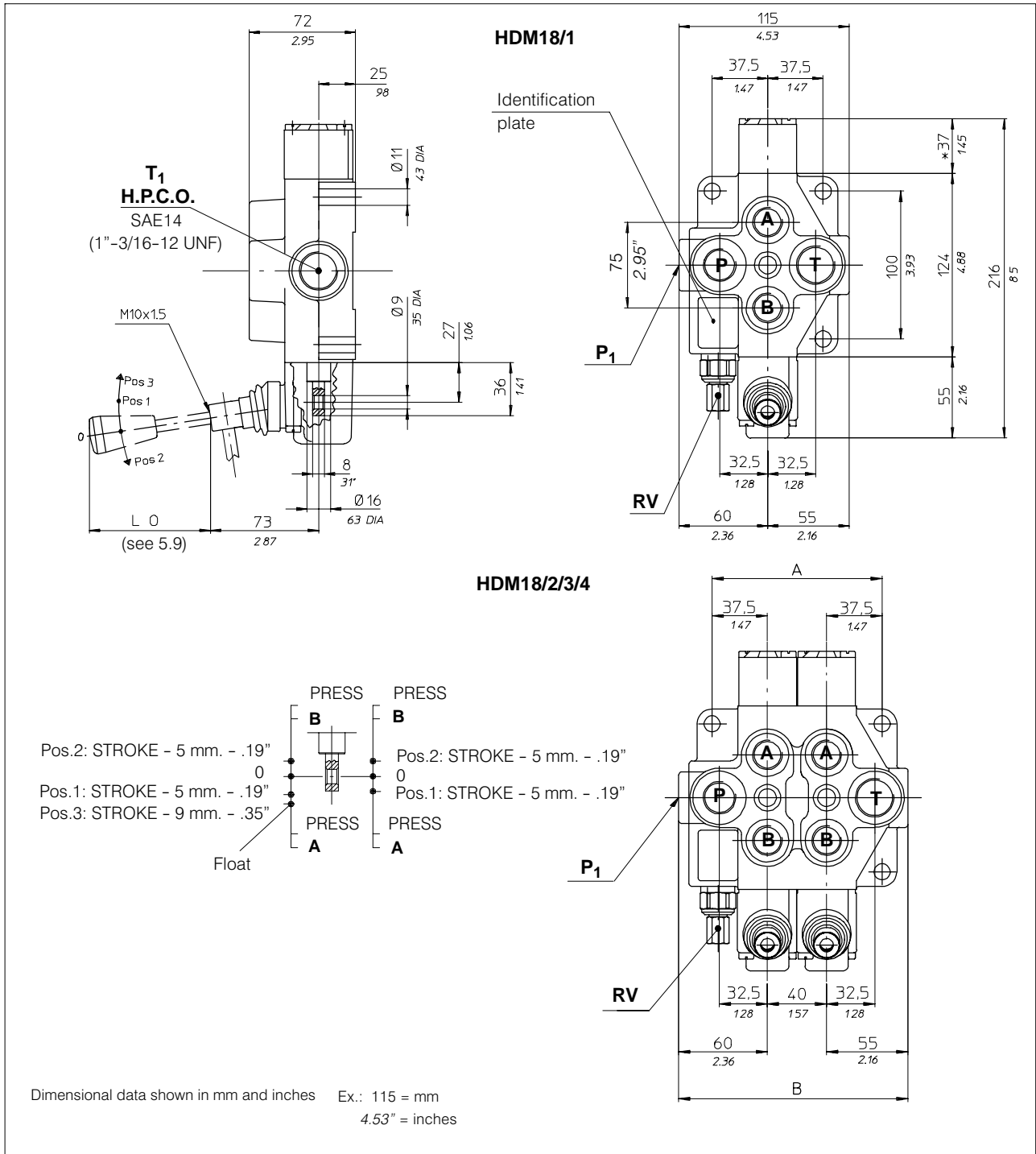

N. of sections		HDM18/2	HDM18/3	HDM18/4
Dimension	A	115 4.53"	155 6.11"	195 7.69"
	B	155 6.11"	195 7.69"	235 9.25"

5.3 Performance curves

Oil: Shell Tellus T37
 Temperature: 50° C (120° F)
 Viscosity: 27 mm²/s

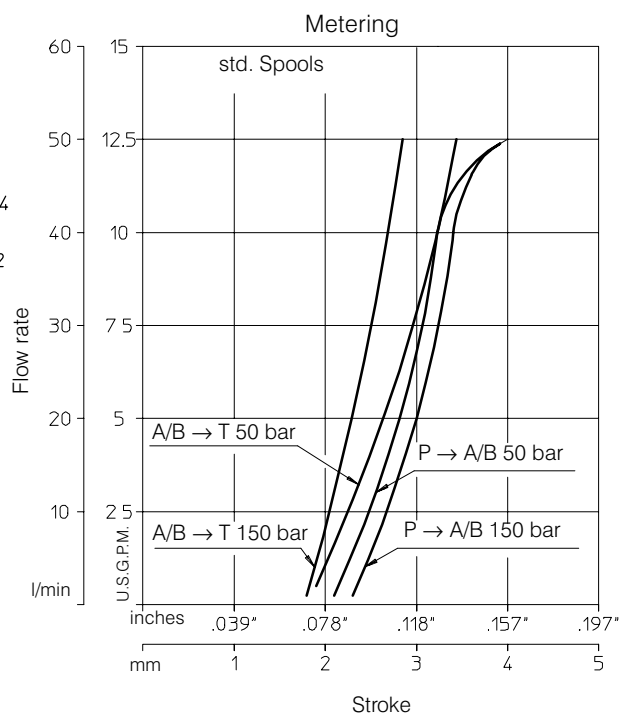
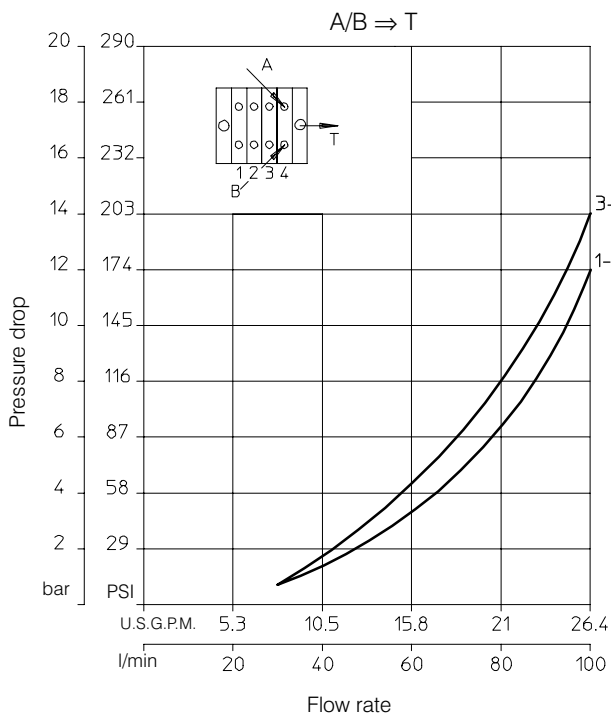
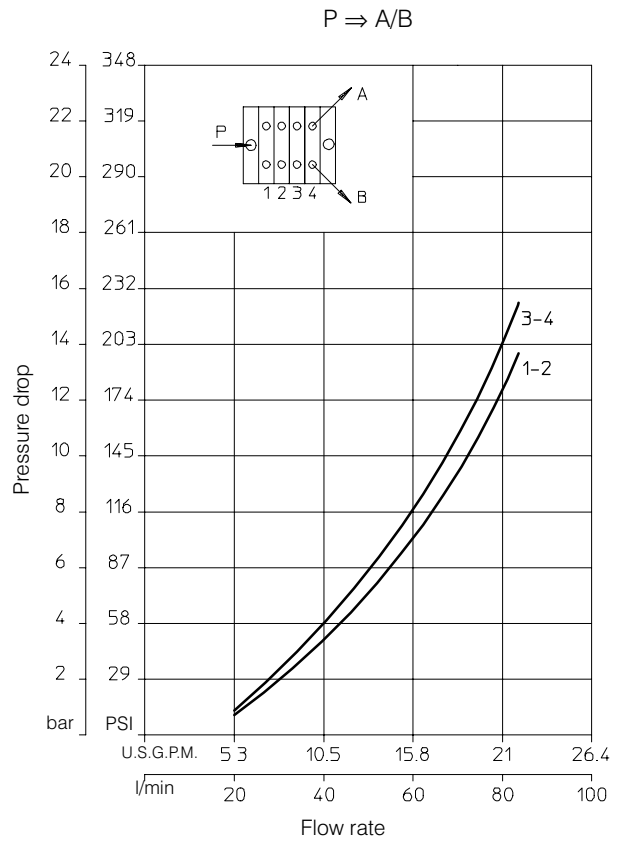
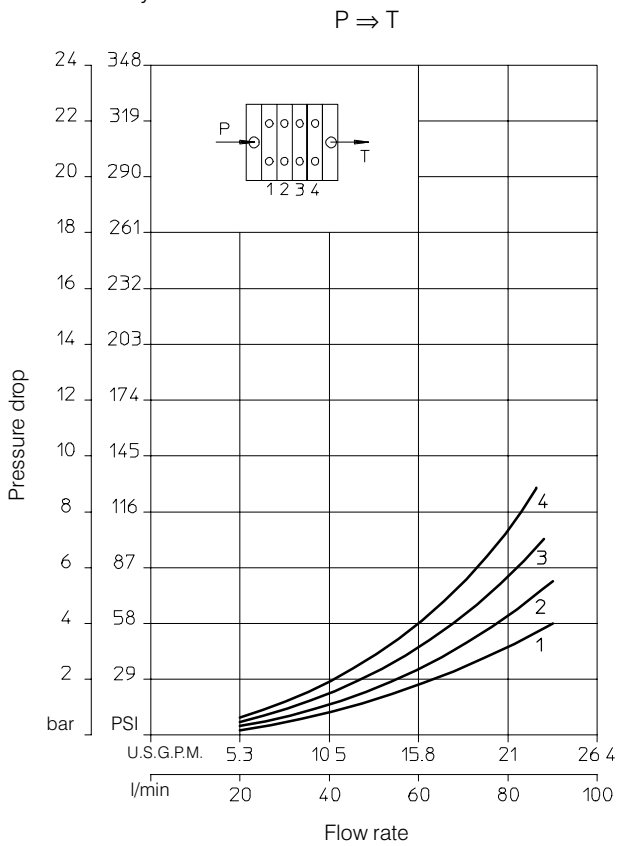

5.4 Monobloc bodies

**5.4.1 Standard circuits: parallel
Open centre with P – T – RV**

P	A/B	T	Type/Code			
			HDM18/1	HDM18/2	HDM18/3	HDM18/4
M18X1.5	M18X1.5	M18X1.5	K01 200.9441.1001.0	K01 200.9442.1001.0	K01 200.9443.1001.0	K01 200.9444.1001.0
M18X1.5	M18X1.5	M22X1.5	K03 200.9441.1002.0	K03 200.9442.1002.0	K03 200.9443.1002.0	K03 200.9444.1002.0
1/2" BSP	1/2" BSP	1/2" BSP	K02 200.9441.3006.0	K02 200.9442.3004.0	K02 200.9443.3006.0	K02 200.9444.3002.0
1/2" BSP	1/2" BSP	3/4" BSP	K05 200.9441.3007.0	K05 200.9442.3005.0	K05 200.9443.3007.0	K05 200.9444.3003.0
SAE10	SAE10	SAE10	K04 200.9441.8004.0	K04 200.9442.8003.0	K04 200.9443.8003.0	K04 200.9444.8003.0
SAE10	SAE10	SAE12	K06 200.9441.8005.0	K06 200.9442.8004.0	K06 200.9443.8004.0	K06 200.9444.8004.0

**5.4.2 Standard circuits: parallel
Open centre and carry-over with P – T – RV
H.P.C.O**

P	A/B	T - HPCO	Code			
			HDM18/1	HDM18/2	HDM18/3	HDM18/4
M18X1.5	M18X1.5	M18X1.5	K21 200.9441.1003.0	K21 200.9442.1003.0	K21 200.9443.1003.0	K21 200.9444.1003.0
M18X1.5	M18X1.5	M22X1.5	K23 200.9441.1004.0	K23 200.9442.1004.0	K23 200.9443.1004.0	K23 200.9444.1004.0
1/2" BSP	1/2" BSP	1/2" BSP	K22 200.9441.3008.0	K22 200.9442.3006.0	K22 200.9443.3008.0	K22 200.9444.3004.0
1/2" BSP	1/2" BSP	3/4" BSP	K25 200.9441.3009.0	K25 200.9442.3007.0	K25 200.9443.3009.0	K25 200.9444.3005.0
SAE10	SAE10	SAE10	K24 200.9441.8006.0	K24 200.9442.8005.0	K24 200.9443.8005.0	K24 200.9444.8005.0
SAE10	SAE10	SAE12	K26 200.9441.8007.0	K26 200.9442.8006.0	K26 200.9443.8006.0	K26 200.9444.8006.0

Note: Body codes consist of: machined casting, seals, plugs and check valve only. Not to be used for complete valve order.

5.4.3 Optional circuits: series and tandem
Open centre with P – T – RV

P	A/B	T	Type/Code			
			HDM18/1	HDM18/2	HDM18/3	HDM18/4
M18X1.5	M18X1.5	M18X1.5	K31	K31	K31	K31
M18X1.5	M18X1.5	M22X1.5	K33	K33	K33	K33
1/2" BSP	1/2" BSP	1/2" BSP	K32	K32	K32	K32 200.9444.3006.0
1/2" BSP	1/2" BSP	3/4" BSP	K35	K35 200.9442.3008.0	K35	K35
SAE10	SAE10	SAE10	K34	K34	K34	K34
SAE10	SAE10	SAE12	K36	K36	K36	K36

5.4.4 Optional circuit: load sensing
Closed centre for variable-displacement pump with P – T – RV and L.S.

P	A/B	T	Type/Code			
			HDM18/1	HDM18/2	HDM18/3	HDM18/4
M18X1.5	M18X1.5	M18X1.5	K61 200.9441.1006.0	K61	K61	K61
M18X1.5	M18X1.5	M22X1.5	K63	K63	K63	K63
1/2" BSP	1/2" BSP	1/2" BSP	K62	K62	K62	K62
1/2" BSP	1/2" BSP	3/4" BSP	K65	K65 200.9442.3009.0	K65	K65
SAE10	SAE10	SAE10	K64	K64	K64	K64
SAE10	SAE10	SAE12	K66	K66	K66	K66

Note: Body codes consist of: machined casting, seals, plugs and check valve only. Not to be used for complete valve order.
For availability of -K- bodies without code please contact our Sales Department.

5.5 Adjustable direct acting Relief Valve RV

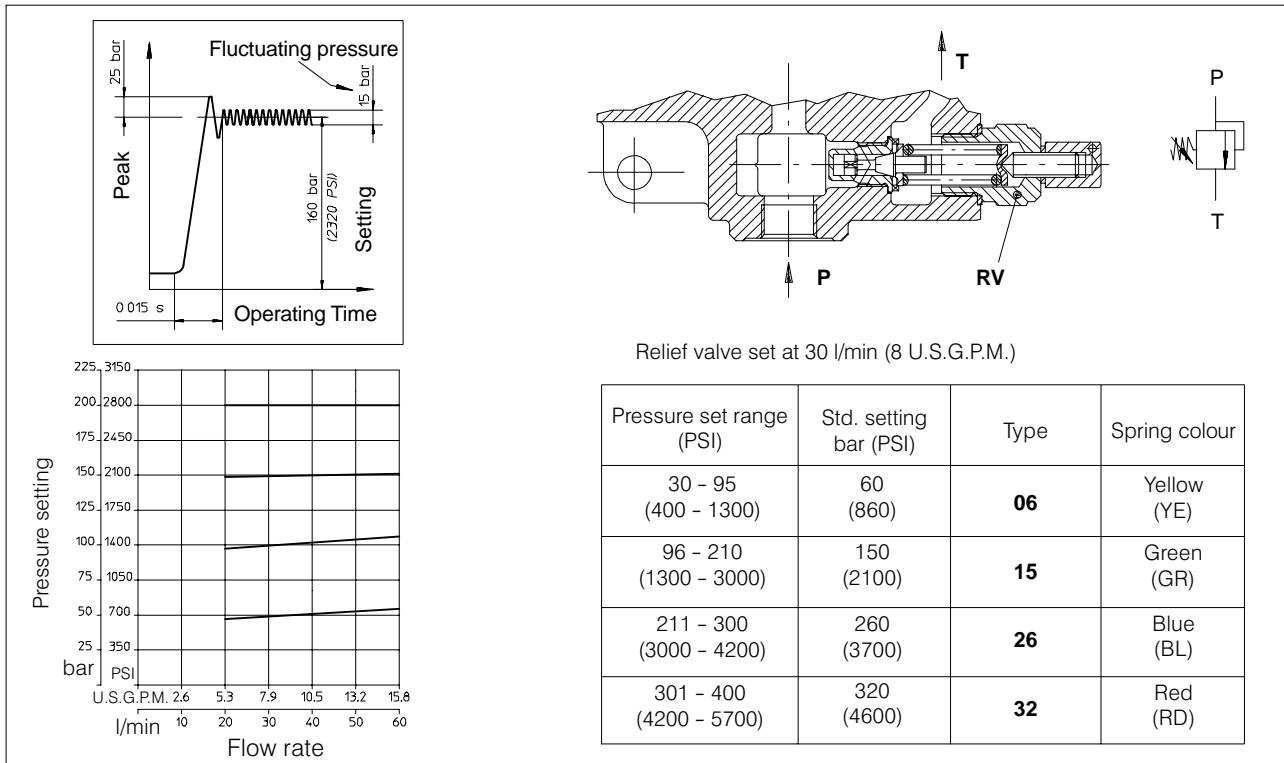

5.6 Spool charts

Spool scheme	Spool features	Type
	4 way - 3 position A/B closed E open by pass	A AS*
	4 way - 3 position A/B-E closed	B
	4 way - 3 position A/B to tank in neutral E open by pass	C CS*
	4 way - 3 position A closed B to tank in neutral	D
	3 way - 3 position B closed E open by pass	G GS*
	4 way - 3 position B closed A to tank in neutral	L
	4 way - 3 position with differential spool in 2 nd position	R**
	3 way - 3 position A closed E open by pass	S SS*

	4 way - 3 position series connection	X XS*
	4 way - 3 position A/B to tank in neutral series connection	XC
	4 way - 4 position 4 th float position	Z ZS*
	4 way - 3 position A/B closed Load Sensing	** LSA
	4 way - 3 position A/B to tank in neutral Load Sensing	** LSC
	3way - 3 position B closed Load Sensing	** LSG
	3 way - 3 position A closed Load Sensing	** LSS
** : special body required		
* : High metering spool (max. flow suggested 40 l/min)		

Note: For availability of L/S versions please contact our Sales Department

5.7 Load Sensing

Load-sensing control and working principle

Through the use of variable flow pumps provided with a pressure and flow compensator the pressure and flow parameters can be adapted according to the different and real working conditions.

These pumps require the use of special valves provided with Load Sensing control which "feels" the hydraulic components (cylinder and motor) requirements and through a special pilot line (L.S.) controls the pump compensator conforming capacity and pressure to such requirements which can be variable in time within the limits of the pump performance.

The L.s. option requires specific bodies and spools. Please ask to Bucher Hydraulics S.p.A. for their availability

The Load Sensing brings following advantages:

- Energy saving.
- Smaller heat exchangers can be used due to a smaller heat energy dissipation.
- Longer life of the pump and driving motor, due to reduced heavy working cycles.
- Excellent control of the load by using 100% of the spool metering.

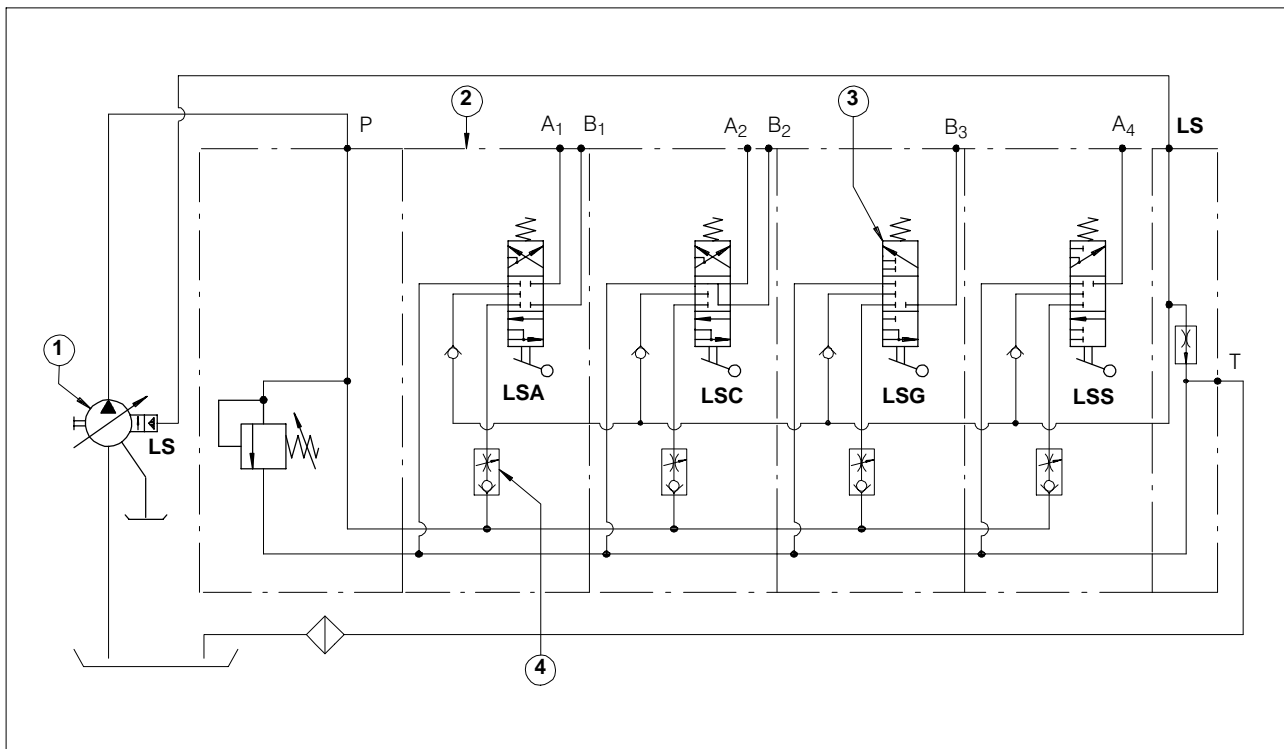

- Variable flow pump provided with pressure and flow compensator.
- Load Sensing valve.

- Special spools: LSA – LSC – LSG – LSS
- Check valve provided with max flow control

5.8 Spool positioners

Spool position				Stroke mm	Type	Code
3	1	0	2			
	○	*	○	5	08	200.9686.1008.0
	●	●	○	5	10	200.9686.3004.0
	●	●	●	5	17	200.9686.2014.0
	○	●	●	5	20	200.9686.3009.0
		●	●	5	25	200.9686.2015.0
	*		○	10	27	200.9686.1044.0
		*	○	5	29	200.9686.3025.0
	○	*	○	5	30	200.9686.1048.0
	○	*	○	5	32	200.9686.1061.0
	○	*	○	5	34	200.9686.1065.0
	●		●	10	36	200.9686.2017.0
	○		*	10	37	200.9686.1066.0
	○	*		5	38	200.9686.1069.0
	○	*	○	5	79	200.9686.1091.0
	○	*	○	5	84	200.9686.1098.0
	○	*	○	5	133	200.9686.1031.0
●	○	*	○	4- 5- 5	136	200.9686.4012.0

- * Initial hand lever position
- Hand lever in detent position
- Spring return position of hand lever

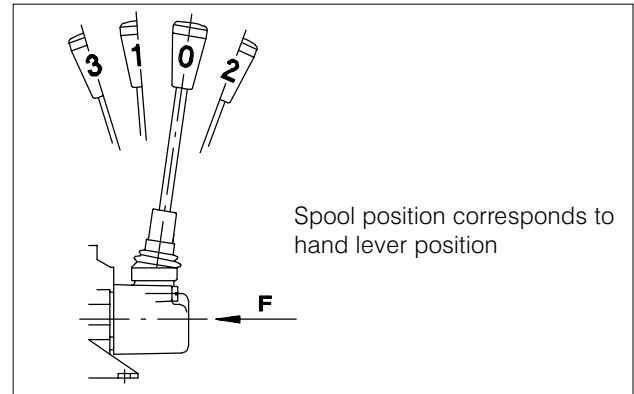

F (N) = Force in Newton (N) needed to operate the spool

F (N)	Spool position control
260	08
130	79
190	133 (standard)

Note: consult factory for different configurations.

5.8.1 Spool positioners dimensions

Spool positioners 08 – 38 – 79 – 133	Spool positioners 10 – 17 – 20 – 25 – 27 29 – 36 – 37	Spool positioner (Z spool type) 136	Spool positioner 84

5.8.2 Microswitch control

Type 30	Microswitch is operated when the spool is in pos.1		
Type 32	Microswitch is operated when the spool is in pos.2		
Type 34	Microswitch is operated when the spool is in pos.1 and 2		

The microswitch is supplied only on customer's request.

5.9 Lever styles

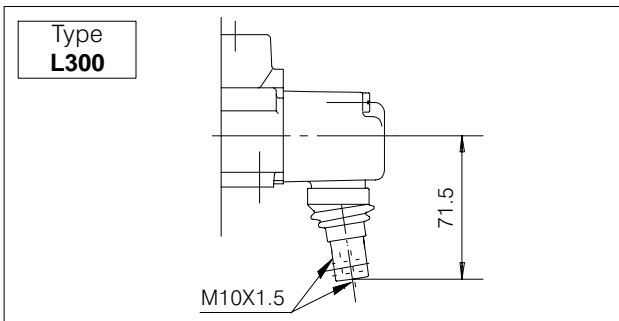
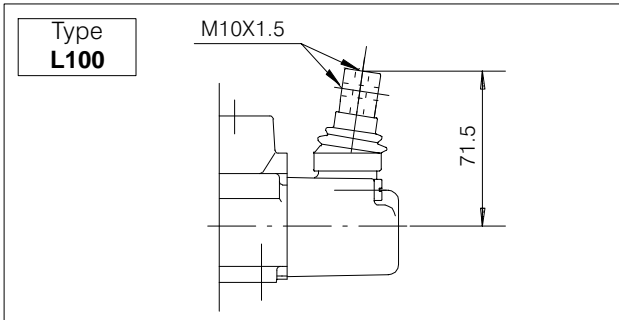
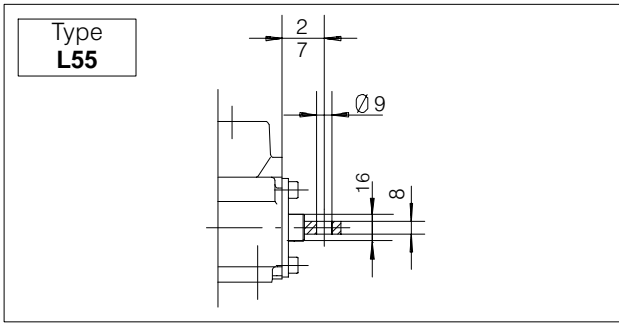

L0		Type	Code
mm	inches		
185	7.28	AL001	200.7022.2001.0
250	9.84	AL002	200.7022.2003.0
300	11.81	AL003	200.7022.2004.0
350	13.78	AL004	200.7022.2005.0

5.9.1 Safety levers

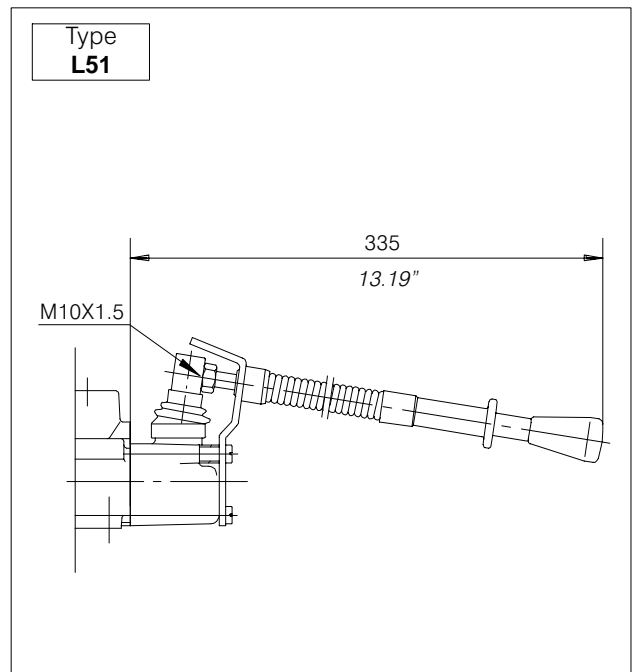
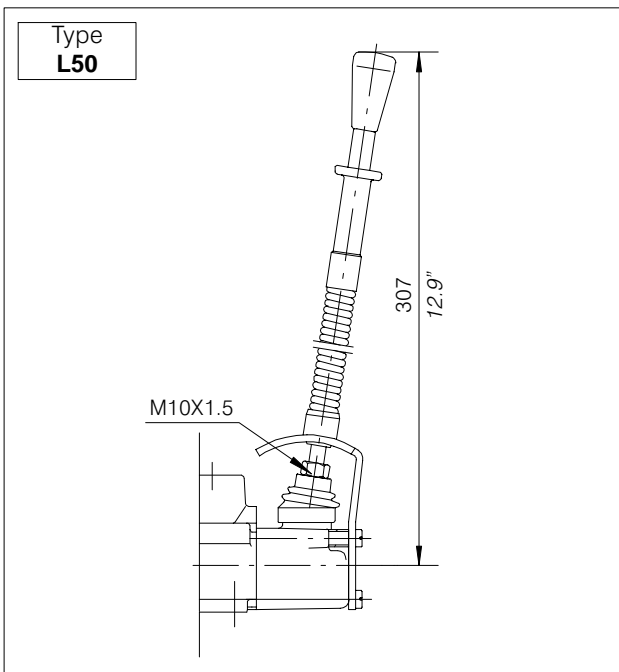

5.9.2 Remote cable control

Lever Support	Code 200.7609.0013.0
----------------------	-------------------------

M10X1.5

Optional
200.6772.0048.0

Lo		Type	Code
mm	inches		
185	7.28	AL001	200.7022.2001.0
250	9.84	AL002	200.7022.2003.0
300	11.81	AL003	200.7022.2004.0
350	13.78	AL004	200.7022.2005.0

Cable	Cable length	Code
--------------	--------------	------

1000 mm	200.5441.04002
1500 mm	200.5441.04005
2000 mm	200.5441.04006
2500 mm	200.5441.04007
3000 mm	200.5441.04008
4000 mm	200.5441.04009

Cables are assembled on the valve only on request and with an extra charge.

Spool Kit

Code 200.9609.0001.0

Type L142	Code 200.7071.2012.0
------------------	-------------------------

M10X1.5

122 4.8"

42 1.65"

MBX1.25

150 5.9"

35 1.38"

40 1.57"

68 2.68"

40 1.57"

Optional
200.6772.0048.0

Only for rod remote control

Type L133	Code 200.9759.3009.0
------------------	-------------------------

L133-L134 are supplied complete with rubber boot protection

View from X

Fulcrum

Spool

Stick Lever M12X1.75

(AL010)

Type L134	Code 200.9759.3009.0
------------------	-------------------------

View from X

(AL010) Stick Lever M12X1.75

Spool

Fulcrum

5.9.3 Cross joystick for dual axis spool control

Type AL010	Code 200.7022.3004.0
-------------------	-------------------------

Lo=250

M12X1.75

5.10 Hydraulic-Pneumatic control ON-OFF

Type	Code
HP 24	200.9686.5011.0

Operating conditions
 Hydraulic:
 Pressure range: (bar) Min. 6 - Max. 15
 (PSI) Min. 85 - Max. 215
 Pneumatic:
 Pressure range: (bar) Min. 6 - Max. 10
 (PSI) Min. 85 - Max. 145

5.11 Pneumatic controls

5.11.1 Pneumatic proportional control

Type	Code
PP 150	200.9686.5009.0

5.11.2 Electro-pneumatic control ON-OFF

Voltage	Type	Code
12 VDC	EP 77	200.9686.6023.0
24 VDC	EP 78	200.9686.6026.0

Electrical data
 Insulation class H - 180° C (356° F)
 Encapsulation material: nylon
 Temperature range:
 -10° C to 80° C (14° F to 170° F)
 Duty cycle: 100% at 68° F ambient
 Voltage variation: -10% to + 15% of nominal voltage
 Power consumption DC - 10 W
 Electrical connection: DIN43650/A (2P + E)
 Cable connection PG9
 Protection class: IP65 (with connector)

Operating conditions
 Pressure range: (bar) Min. 6 - Max. 10
 (PSI) Min. 85 - Max. 145
 Ambient temperature: -10° C to 50° C (14° F to 122° F)
 Response time: 6 - 8 milliseconds
 Mounting in any position

5.12 Hydraulic Proportional control

Type	Code
HP 50	200.9686.5019.0

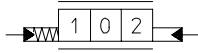

Joystick adjustment diagram

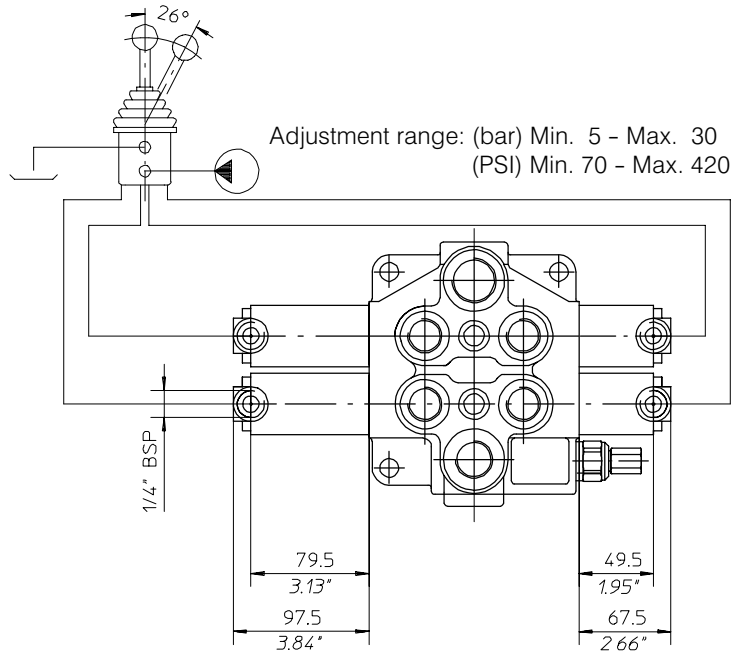
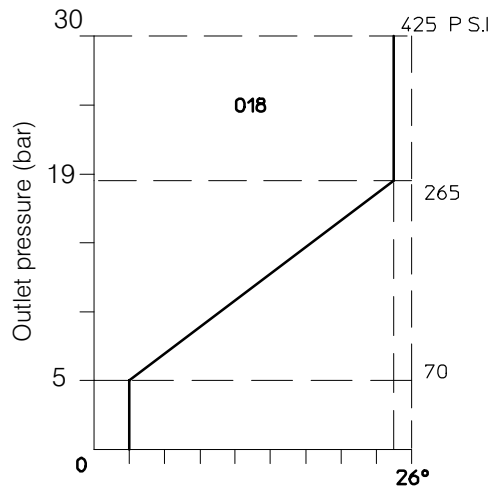

5.13 Electro-Hydraulic controls

**5.13.1 Electro-hydraulic control internal pilot version
ON-OFF with pressure reducing valve**

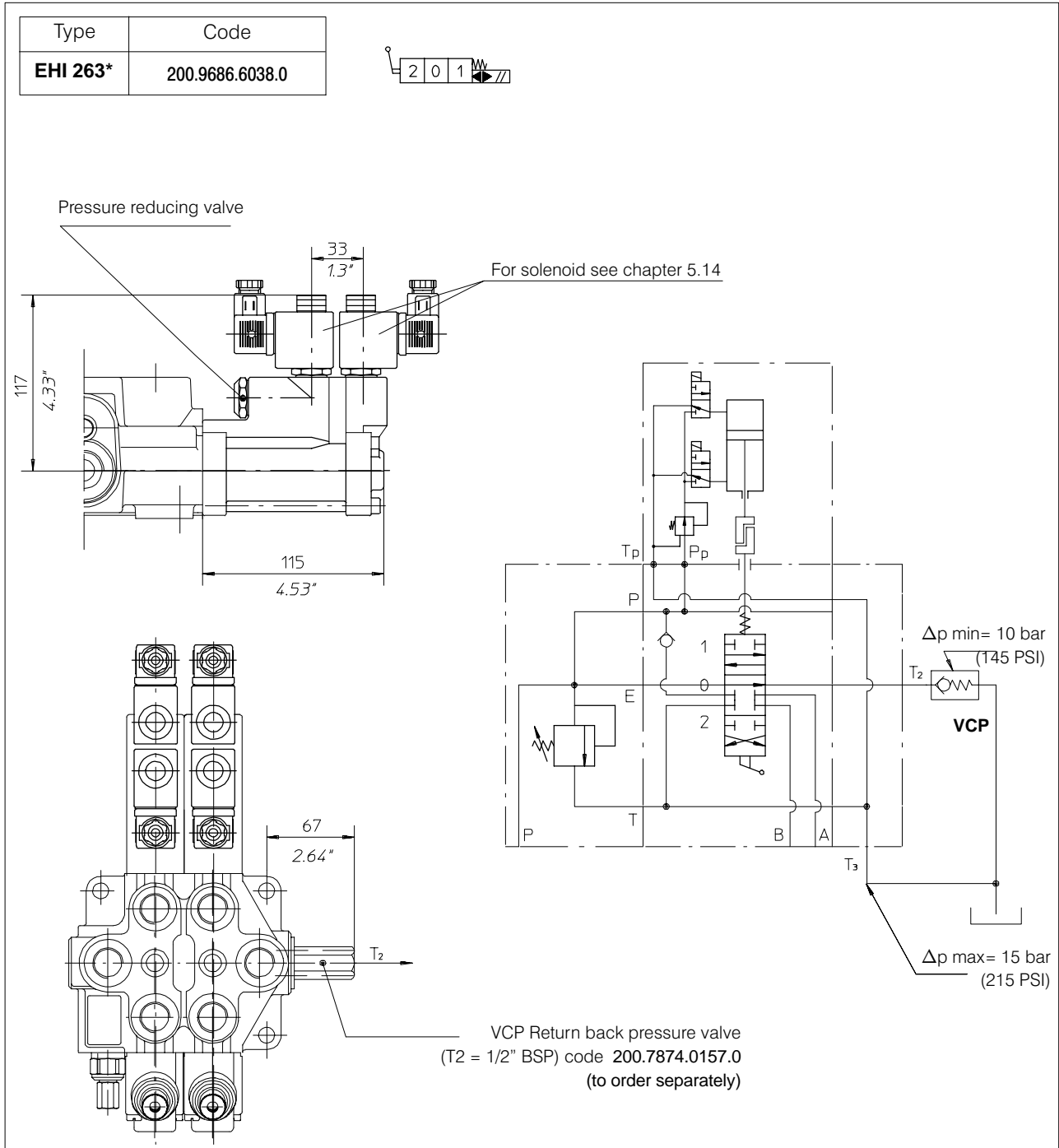

Mechanical and hydraulic features

Max pressure on P_p port 300 bar (4200 PSI)
 Reduced pressure after pressure reducing valve 10 bar (145 PSI)
 Fixed delivery on P_p pilot line 1 l/min (0.26 U.S.G.P.M)

Leakage of pressure reducing valve (in neutral pos.) 100 ml/min (6.1 in³/min)
 Min. suggested filtration 25 micron
 Operating oil temperature min.-30°C- max. 90°C
 min.-22°F - max 194°F

* EHI 263: special body required.

5.13.2 Electro-hydraulic controls external pilot version ON-OFF

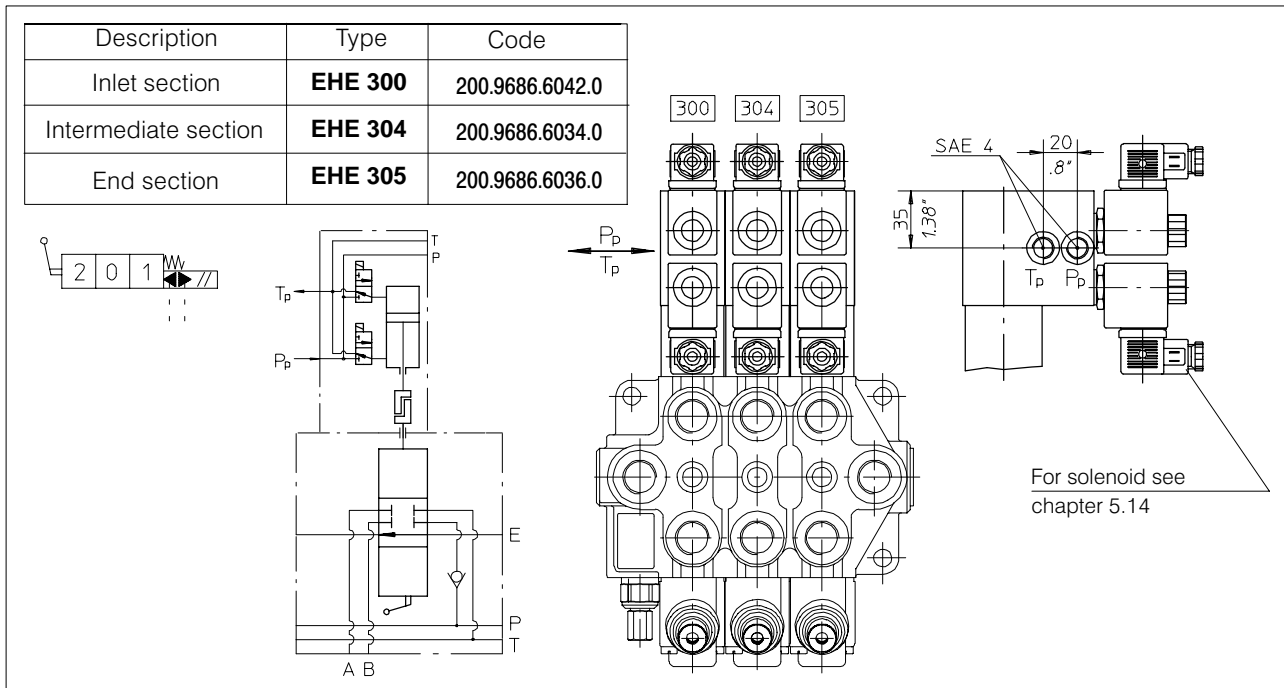

5.13.3 Electro-hydraulic control external pilot version ON-OFF with pressure reducing valve on inlet manifold

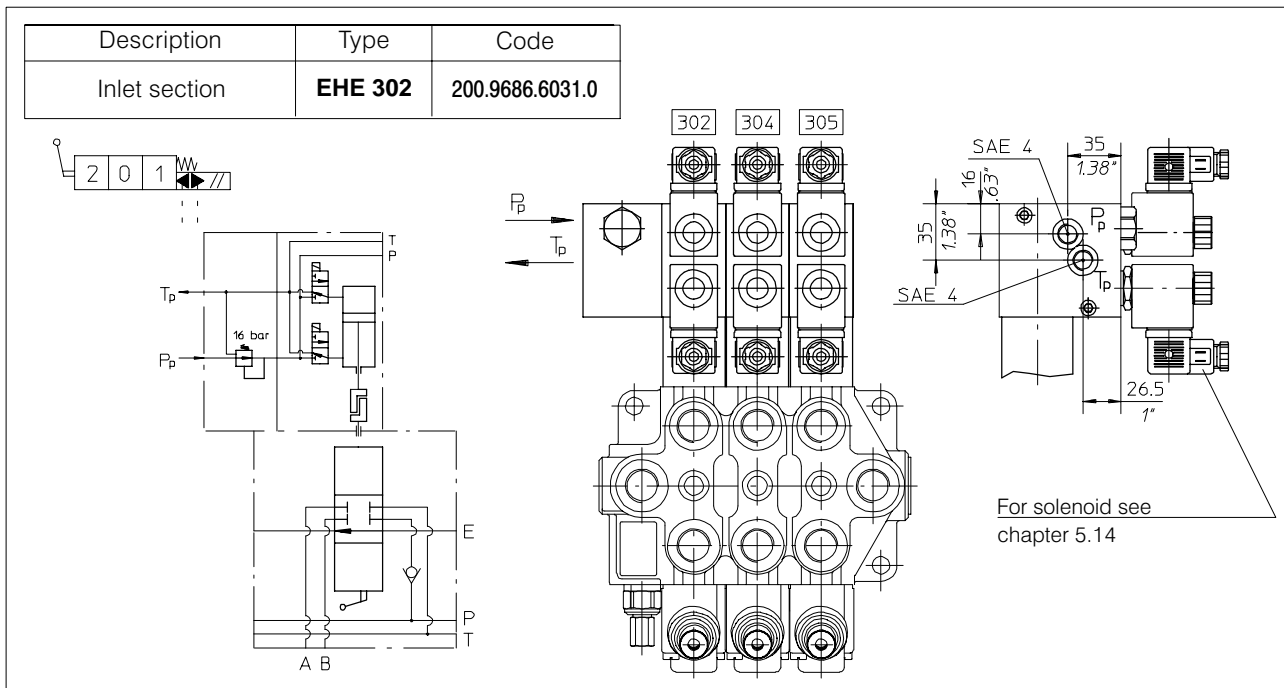

Mechanical and hydraulic features

Pilot pressure min. 10 bar (140 PSI)
 Pilot pressure max. 30 bar (420 PSI)
 Pilot pressure with pressure reducing valve 12 bar (175 PSI)
 Pilot flow to each working section 1 l/min (0.26 U.S.G.P.M.)

Operating oil temperature min. -30°C - max. 90°C
 min. -22°F - max. 194°F
 Leakage of pressure reducing valve (in neutral pos.) 100 ml/min (6.1 in³/min)
 Min. suggested filtration 25 micron

5.14 Solenoids for pilot electrovalves EHI-EHE

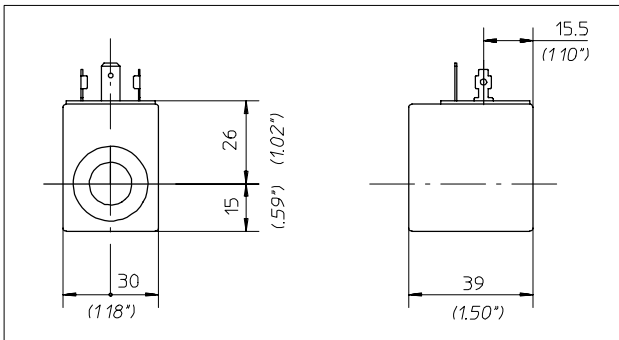

Wire class	F (VDE 0580)
Coil insulation	IP65 (DIN 40050)
Duty rating	ED 100%
Stabilized temperature	70 °C
Voltage tolerance	± 10%

Supply Voltage	Nominal coil voltage	Power (Watt)	Resistance (Ohm)		Current (Ampere)		Coil code
			Ambient temperature	Stabilized temperature	Ambient temperature	Stabilized temperature	
12 V. DC	12 V. DC	18.7	7.7	10.8	1.56	1.11	200.6749.1003.0
24 V. DC	24 V. DC	18.6	31	41.4	0.77	0.58	200.6749.2003.0
24 V. AC	21.6 V. DC	17.3	27	36	0.80	0.60	200.6748.2003.0
110 V. AC	98 V. DC	15.6	630	825	0.157	0.120	200.6748.4003.0
220 V. AC	198 V. DC	15.7	2500	3300	0.08	0.06	200.6748.6003.0

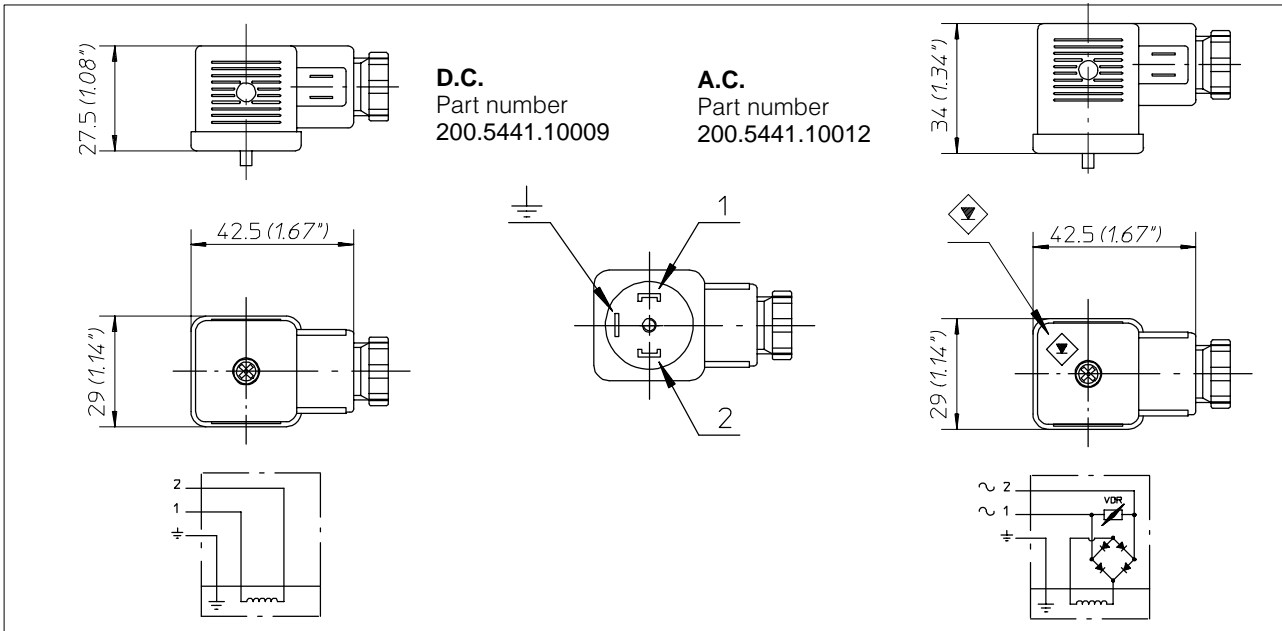

Armour clamp	Pg 9
Ø cable	6 - 8 mm
Diodes	1N 4007 GP
Overvoltage protection	VDR
Connector type	DIN 43650
Number of poles	2 + \perp
Supply voltage	max. 220 V
Nom. capacity at contacts	10 Ampere

Max capacity at contacts	16 Ampere
Resistance at contacts	≥ 4 mOhm
Max section of cable	1.5 mm ²
Outer material	Glass fibre reinforced nylon
Protection factor	IP65 (DIN 40050)
Insulation class	C (VDE 0110)
Temperature range	-40° +90°C

5.15 Electromagnetic controls ON-OFF

+

Voltage	Type	Code
12 VDC	EPP 344*	200.9686.1179.0
24 VDC	EPP 343*	200.9686.1180.0

The technical drawing shows the HDM18 valve with dimensions: 155 mm (6.10") total length, 89.5 mm (3.52") height, 54 mm (2.13") coil height, and 59 mm (2.32") coil width. It includes a 3-position selector switch (2, 0, 1) and a 3-position hydraulic spool (1, 2, 3). The spool positions are labeled: B=1-2 (PULL) and A=1-3 (PUSH). The electrical diagram shows a 3-position selector switch with terminals 2, 0, 1 and a 3-position hydraulic spool with terminals 1, 2, 3. The coil is connected to terminals 1 and 2.

* special body required

To be used with special spools only: the spool definition is different from the standard one because of the double "P". For example A spool become AP3. Ex.: (A spool + 24 VDC positioner)= AP3343

Mechanical and hydraulic features

Max operating pressure 150 bar (2800 PSI)
 Max flow 40 l/min (15 U.S.G.P.M.)
 Max back pressure 5 bar (70 PSI)
 Operating oil temperature 80° C (180° F)

Electromagnetic specification

Input tension 12 V DC [24 V DC] ± 10%
 Power consumption 60 W
 ED: 100 %

Ohms resistance (cold T°): 2.4 Ω [9.6 Ω]
 Ohms resistance (stabilized T°): 3.1 Ω [12.5 Ω]
 Intensity of current (cold T°) 5 A (2.5 A)
 Intensity of current (stabilized T°) 3.8 A (1.9 A)
 Ambient operating temperature range: -25°C/+60°C
 Average stabilized coil temperature operated continuously +105°C
 The above mentioned average temperature is obtained with a nominal voltage of 12 V (24 V), with an ambient temperature of 25° C and with an electromagnet assembled on a hydraulic valve with oil circulation.
 Insulation class: according to VDE 0580 standard H
 Electrical connection: with Hirschmann connector per DIN 43650 IP 65

BUCHER HYDRAULICS

www.bucherhydraulics.com

Germany

Phone +49 7742 85 20
Fax +49 7742 71 16
info.de@bucherhydraulics.com

France

Phone +33 389 64 22 44
Fax +33 389 65 28 78
info.fr@bucherhydraulics.com

Netherlands

Phone +31 79 34 26 24 4
Fax +31 79 34 26 28 8
info.nl@bucherhydraulics.com

UK

Phone +44 24 76 35 35 61
Fax +44 24 76 35 35 72
info.uk@bucherhydraulics.com

USA

Phone +1 262 605 82 80
Fax +1 262 605 82 78
info.wi@bucherhydraulics.com

Switzerland

Phone +41 33 67 26 11 1
Fax +41 33 67 26 10 3
info.ch@bucherhydraulics.com

Italy

Phone +39 0522 92 84 11
Fax +39 0522 51 32 11
info.it@bucherhydraulics.com

Austria

Phone +43 6216 44 97
Fax +43 6216 44 97 4
info.at@bucherhydraulics.com

China

Phone +86 10 64 44 32 38
Fax +86 10 64 44 32 35
info.bj@bucherhydraulics.com

Product Center (Elevator)

Phone +41 41 757 03 33
Fax +41 41 755 16 49
info.nh@bucherhydraulics.com

We reserve the right of modification without prior notice.