

GROUP 2 PUMPS - EUROPEAN STANDARD HERCULES SERIES

VERSION: G28 P2

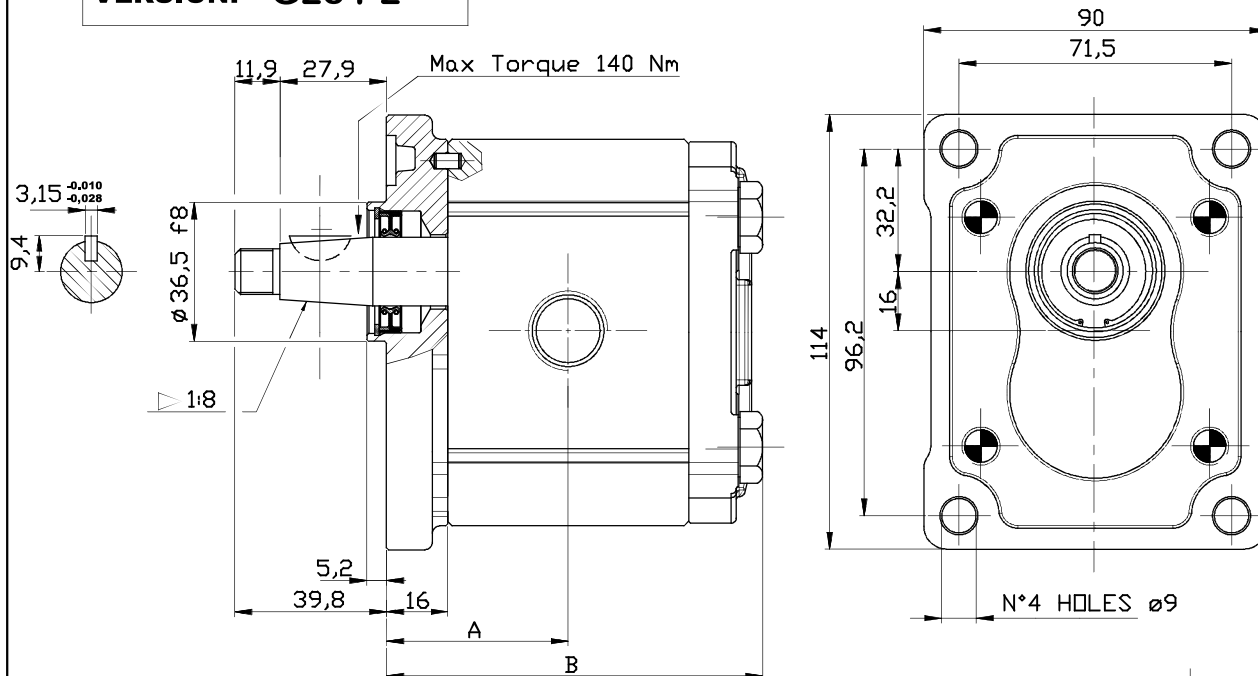

Type	Displacement (cc/rev)	Max working pressure P1 (bar)	Peak pressure P3 (bar)	Max speed (r.p.m)	Dimension		Inlet port		Outlet port	
					A	B	e	d	e	d
OT 200 P04	04,10	280	330	4000	40,00	83,50	G1/2	14	G1/2	14
OT 200 P06	06,20	280	330	3500	41,50	86,50	G1/2	14	G1/2	14
OT 200 P08	08,20	280	330	3500	43,00	89,50	G1/2	14	G1/2	14
OT 200 P11	11,20	280	330	3500	45,15	93,80	G1/2	14	G1/2	14
OT 200 P14	14,00	280	330	3000	47,15	97,80	G3/4	16	G1/2	14
OT 200 P16	16,00	270	330	3000	48,60	100,7	G3/4	16	G1/2	14
OT 200 P20	20,00	225	265	3000	51,50	106,5	G3/4	16	G1/2	14
OT 200 P22	22,50	190	230	2500	57,35	118,2	G3/4	16	G1/2	14
OT 200 P25	25,10	190	230	2500	59,25	122,0	G3/4	16	G1/2	14

EXAMPLE OF ORDERING CODE

OT20H P 08 S / G 28 P2 - A

Series

Pumps

Pump displacement

Rotation

S Anti-clockwise

D Clockwise

Bushings

A Alluminium

B Bronze

European standard flange

Taper shaft (1:8)

Body with threaded ports (BPS)



AVAILABLE FOR QUANTITIES