

AD.5.E...J* VALVES WITH SPOOL MOVEMENT SPEED CONTROL VARIANT J*



1

Valves type AD5.E... with spool movement speed control variant J*

These ON-OFF type valves are used when a lower spool movement speed than usual for conventional solenoid valves is required to prevent impacts which could adversely affect the smooth running of the system. The system consists of reducing the transfer section for the fluid from one solenoid to the other by means of calibrated orifice.

• This version can only be used with a direct current (DC) and also involves a **reduction in the limits of use so that we suggest to always test the valve in your application.**

- To order AD.5.J* version valves, specify the orifices code.
- The operation is linked to a minimum counter-pressure on the T line (1 bar min.)
- The switching time referred to the spool travel detected by a LVDT transducer can vary for the NG10 valve a minimum of 200 to a maximum of 400 ms depending on 5 fundamental variables:

- 1) Diameter of the calibrated orifice (see table)
- 2) Hydraulic power for clearance referring to flow and pressure values through the valve
- 3) Spool type
- 4) Oil viscosity and temperature
- 5) Counter-pressure at T line

• **Possible mounting: C / E / F / G / H**

• **19 / 20 / 21 spools not planned for variant J***

CALIBRATED ORIFICE AVAILABLE		
ø (mm)	M6x6	Code
0.5	M89.10.0031	J5
0.6	M89.10.0026	J6
0.7	M89.10.0032	J7
0.8	M89.10.0033	J8

EAD5E...J\$ - 00/2000/e

Max. pressure ports P/A/B	320 bar
Max. pressure port T - see note (*)	250 bar
Max. flow	100 l/min
Duty cycle	100% ED
Fluid viscosity	10 ÷ 500 mm ² /s
Fluid temperature	-25°C ÷ 75°C
Ambient temperature	-25°C ÷ 60°C
Weight with one DC solenoid	3,6 Kg
Weight with two DC solenoids	4,5 Kg

(*) Pressure dynamic allowed for 2 millions of cycles.

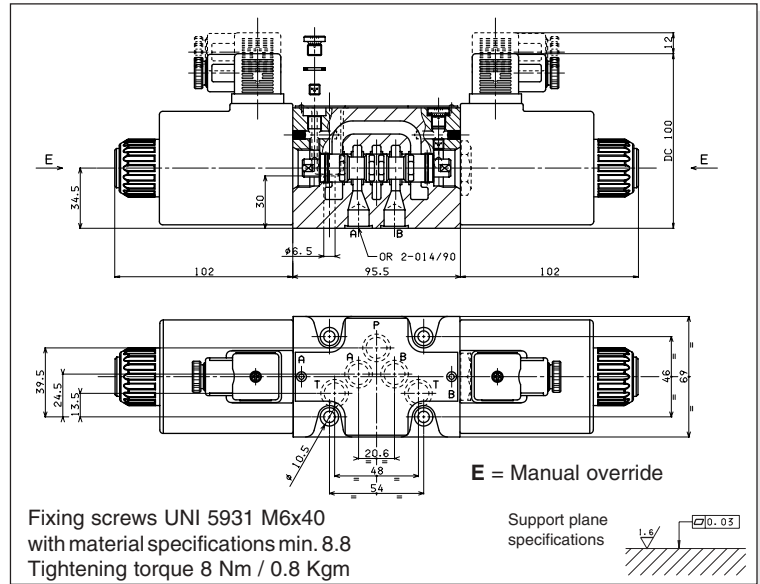

AD.5.E...Q5 VALVES WITH EXTERNAL DRAINING SOLENOID - VARIANT Q5



Valves type AD5.E... variant Q5 with external draining solenoid

This involves valves with solenoid drainage chambers separated by line T in the CETOP 5 interface distinguished by the letter L. This solution makes it possible to operate with a maximum counter-pressure at T up to 320 bar using only 12.9 material fixing screws to ensure the maximum safety of the solenoid valve fixing and use of an additional drain. This version can be used for direct current (DC) and alternating current (AC), but involves a reduction in the limits of usage depending on the pressure at T.

• **Mounting possible: C / D / E / F / G / H / I / L / M**

• **For subplate see BSH.5.31..**

Max. pressure ports P/A/B/T	320 bar
Max. pressure port L (DC coils) see note (*)	250 bar
Max. pressure port L (AC coils)	160 bar
Max. flow	100 l/min
Max. excitation frequency	2 Hz
Duty cycle	100% ED
Fluid viscosity	10 ÷ 500 mm ² /s
Fluid temperature	-25°C ÷ 75°C
Ambient temperature	-25°C ÷ 60°C
Weight with one DC solenoid	3,6 Kg
Weight with two DC solenoids	4,5 Kg
Weight with one AC solenoid	3,5 Kg
Weight with two AC solenoids	4,3 Kg

(*) Pressure dynamic allowed for 2 millions of cycles.

OVERALL DIMENSIONS

EAD5E...Q5 - 02/2000/e

